

Fluid Level Gauge Fluid Level Sensor Temperature Switch FSA / FSK / TSE

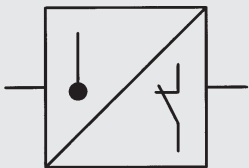

up to size 381
up to PN 0.5 bar
up to T = 80 °C

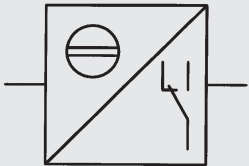
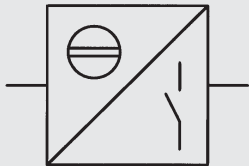
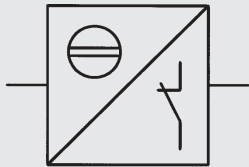
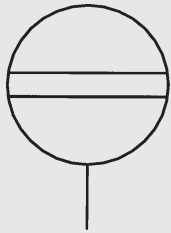

1. DESCRIPTION

1.1. GENERAL

HYDAC fluid level gauges FSA, fluid level sensors FSK and temperature switches TSE are units which serve to monitor and control the level of operating fluid.

The flexible product range means that many combinations are possible:

- FSA: five sizes.

Visual thermometer with °C and °F scale.

Temperature gauge which records the temperature of the operating fluid in the tank; display in °C.

Dual scale in °C and °F is available on request.

Simple, standardised mounting conditions (FSA/K).

- FSK: four sizes.

Switching contact can be either type O (opens when fluid is at low level) or type C (closes when fluid is at low level) or type W (dual switching unit)

Temperature gauge which records the temperature of the operating fluid in the tank; display in °C.

Dual scale in °C and °F is available on request.

Simple, standardised mounting conditions (FSA/K).

- TSE: three nominal temperatures possible: 60 °C, 70 °C and 80 °C.

Can be easily fitted into the FSA and FSK.

Simple, standardised mounting conditions (FSA/K).

Non-corroding surfaces.

1.2. FUNCTION OF THE FSA

By using a HYDAC FSA, the fluid level can be easily seen on the outside of the tank. The fluid enters the unit via the lower connection bore and is clearly visible in the tube. Selection of the correct size allows the respective level of the fluid to be monitored.

FUNCTION OF THE FSK

By using a HYDAC FSK, the fluid level is monitored via an electrical switching signal. This switching signal can be used as a warning message or to regulate the fluid level. The fluid enters the unit via the lower connection bore and pushes up a float in the tube.

The float now shows the level of the fluid in the tank. If the level of fluid drops again, the float activates a switching contact.

On type C the circuit is then closed and on type O the circuit is then open.

The special dual switching model (type W) offers two possibilities. It can either be used to close on contact or to open on contact.

FUNCTION OF THE TSE

The HYDAC TSE is a very useful additional option to the FSA and FSK products. However, it also has a useful application as a separate build-on unit on systems.

The temperature sensor of the TSE, when fitted, is surrounded by operating fluid. When the nominal temperature is reached, a contact opens and the circuit is broken.

This switching process can be used either as a warning message or to monitor the temperature.

When the temperature of the fluid drops by approx. 25 K, the circuit closes again.

1.3. APPLICATION

HYDAC fluid level gauges FSA, fluid level sensors FSK and temperature switches TSE are used to monitor and control levels of operating fluid.

Areas of application are for example:

Machine tools, system engineering, hydraulic oil, lubricating oil and cutting oil tanks as well as gearboxes.

1.4. NOTES

The upper viscosity limit is 2,000 mm²/s.

It is not possible to combine a temperature switch TSE with an FT temperature gauge.

To ensure correct functioning, pressure, viscosity and temperature specifications must be observed.

FSA/FSK

Not suitable for use with glycol or fluids containing glycol.

FSK

Depending on the fluid level of the tank the following switching logic applies.

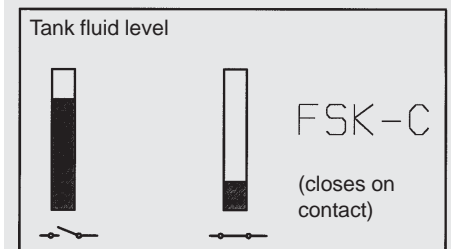
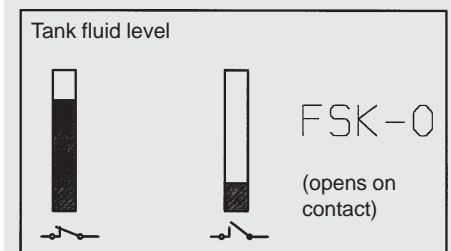

In the FSK type O the switching contact opens when the fluid level drops below the switching level. Correspondingly, in the FSK type C, the switching contact closes when the fluid level drops below the switching level.

2. TECHNICAL SPECIFICATIONS

2.1. GENERAL

2.1.1 Designation and symbol

Fluid level gauge FSA

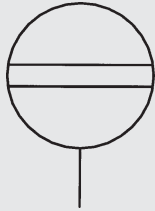

Fluid level sensor FSK

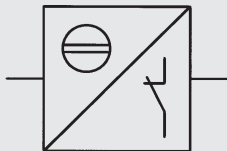

O - N/C contact

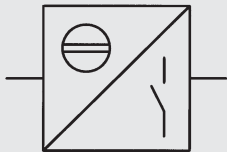

C - N/O contact

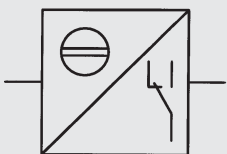

W - N/O or
N/C contact

Temperature switch TSE

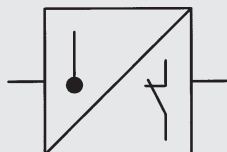

2.1.2 Model code for FSA (also order example)

FSA - 076 - 2 . X / FT200 / 12

Fluid level gauge

Size

≅ centre distance of bolts

076

127

176

254

381

Material of seals

2 = Viton (FKM)

1 = Perbunan (NBR)

Series

(determined by manufacturer)

Additional thermometer function

- = no additional function

T = thermometer in display tube

FT 200 = temperature gauge 200 mm

FT 300 = temperature gauge 300 mm

TSE 60 = temperature switch nominal temperature 60 °C

TSE 70 = temperature switch nominal temperature 70 °C

TSE 80 = temperature switch nominal temperature 80 °C

Mounting

Banjo bolt thread

M 12 (standard)

M 10 (not on TSE)

Model code for FSK (also order example)

FSK - 127 - 2 . X / O / FT200 / 12 / ...

Fluid level sensor

Size

≅ centre distance of bolts

127

176

254

381

Material of seals

2 = Viton (FKM)

Series

(determined by manufacturer)

Switching function

O = opens at the switching level

C = closes at the switching level

W = opens or closes at the switching level

(Hirschmann plug = standard)

Additional thermometer function

- = no additional function

FT 200 = temperature gauge 200 mm

FT 300 = temperature gauge 300 mm

TSE 60 = temperature switch nominal temperature 60 °C

TSE 70 = temperature switch nominal temperature 70 °C

TSE 80 = temperature switch nominal temperature 80 °C

Mounting

Banjo bolt thread

M 12 (standard)

M 10 (not on TSE)

Plug

No details = 3 pole MPM (standard)

Z4 = 4 pole Hirschmann

SEW = 4 pole M12x1 (sensor technology plug)

Model code for TSE

(also order example)

TSE - 70 / X / 12**Temperature switch**

TSE – temperature switch (for FSA)

TSE-L – temperature switch long (for FSK)

Nominal temperature

60 °C

70 °C

80 °C

Series

(determined by manufacturer)

Banjo bolt thread

M 12

2.1.3 Standard models

Type	Size ≙ centre distance of bolts	Order no. = stock no.	Weight [kg]
FSA - 076 - 1.X/-/12	76	700 000	0.17
FSA - 076 - 2.X/-/12	76	700 002	0.17
FSA - 127 - 1.X/-/12	127	700 036	0.19
FSA - 127 - 2.X/-/12	127	700 038	0.19
FSA - 176 - 1.X/-/12	176	700 113	0.22
FSA - 176 - 2.X/-/12	176	700 137	0.22
FSA - 254 - 1.X/-/12	254	700 072	0.24
FSA - 254 - 2.X/-/12	254	700 074	0.24
FSA - 381 - 1.X/-/12	381	700 095	0.29
FSA - 381 - 2.X/-/12	381	700 160	0.29
<hr/>			
TSE - 60 /X/12	–	703 724	0.11
TSE - 70 /X/12	–	703 714	0.11
TSE - 80 /X/12	–	551 481	0.11
<hr/>			
FSK - 127 - 2.X/O/-/12	127	3 070 285	0.21
FSK - 127 - 2.X/C/-/12	127	3 112 276	0.21
FSK - 127 - 2.X/W/-/12/Z4	127	3 112 298	0.21
FSK - 127 - 2.X/O/-/12/SEW	127	3 136 130	0.21
FSK - 176 - 2.X/O/-/12	176	3 112 231	0.23
FSK - 176 - 2.X/C/-/12	176	3 112 299	0.23
FSK - 176 - 2.X/W/-/12/Z4	176	3 112 301	0.23
FSK - 254 - 2.X/O/-/12	254	3 112 302	0.26
FSK - 254 - 2.X/C/-/12	254	3 112 303	0.26
FSK - 254 - 2.X/W/-/12/Z4	254	3 112 305	0.26
FSK - 381 - 2.X/O/-/12	381	3 112 306	0.30
FSK - 381 - 2.X/C/-/12	381	3 112 307	0.30
FSK - 381 - 2.X/W/-/12/Z4	381	3 112 309	0.30
<hr/>			
TSE-L - 60 /X/12	–	3 148 887	0.13
TSE-L - 70 /X/12	–	3 148 886	0.13
TSE-L - 80 /X/12	–	3 148 885	0.13
<hr/>			
FT 200 0 - 100 °C / M12	200	700 154	0.03
FT 300 0 - 100 °C / M12	300	700 155	0.04

2.1.4 Type of construction

The units are designed to be mounted directly on to the operating fluid tank.

2.1.5 Type of connection

FSA / FSK

The unit is mounted using two banjo bolts. The connection bores can either be threaded holes or clearance holes (Ø 13, Ø 11).

TSE

The temperature switch can be fitted to the FSA / FSK in place of the lower banjo bolt.

2.1.6 Mounting position

FSA – vertically
on the tank wall

FSK – vertically
on the tank wall
(connection plug at
the bottom of the tank)

TSE – instead of
lower banjo bolt
M12 (FSA)

TSE-L – instead of
lower banjo bolt
M12 (FSK)

2.1.7 Weight

(See table 2.1.3)

2.1.8 Flow direction

Optional

2.1.9 Ambient temperature

- 20 °C to + 80 °C

2.1.10 Materials

FSA / FSK

- End caps and tube in high quality synthetic material
- Housing in aluminium
- Soft seals in Viton (FKM) or Perbunan (NBR)
- Bolts, nuts and washers in steel (plated)
- Plug connections in high quality synthetic material (FSK)
TSE / TSE-L
- Housing with temperature sensor, washer and nut in steel (zinc-plated)
- Plug connections in high quality synthetic material

2.2. HYDRAULIC DETAILS

2.2.1 Nominal pressure

Max. 0.5 bar

2.2.2 Operating fluids

Mineral oil to DIN 51524, Part 1 and 2, water-oil emulsions and synthetic fluids, such as hydraulic fluids based on phosphate ester (NOT water glycol).

For water glycol, glass tubes are available.

For other fluids, please contact our technical sales department.

2.2.3 Temperature of operating fluid

- 20 °C to + 80 °C

2.2.4 Scale range of thermometer FSA / FSK

Thermometer T for FSA:

+ 20 °C to + 80 °C

Thermometer FT for FSA / FSK:

0 °C to + 100 °C

2.3. ELECTRICAL DETAILS OF FSK

2.3.1 Electrical functions

Type O (Standard)

Opens when fluid at switching level

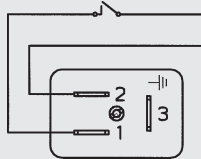

Type O (Hirschmann plug - Z4)

Opens when fluid at switching level

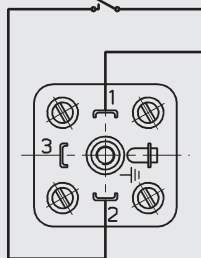

Type O (Sensor technology plug - SEW)

Opens when fluid at switching level

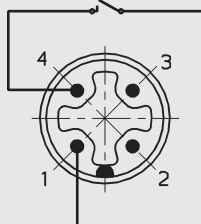

Type C (Standard)

Closes when fluid at switching level

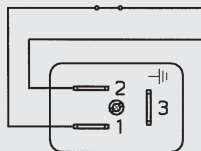

Type W (Standard) (Hirschmann plug - Z4)

Dual switching unit

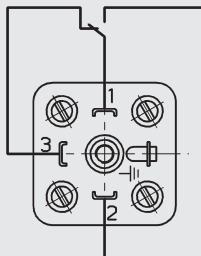

Type W (Sensor technology plug - SEW)

Dual switching unit

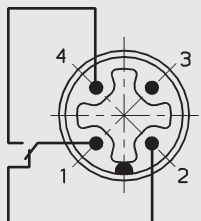

2.3.2 Contact load

Max. 8 W

2.3.3 Switching voltage

50 V AC / DC

2.3.4 Switching current

0.2 A

2.4. ELECTRICAL DETAILS OF TSE / TSE-L

2.4.1 Electrical function

opens on contact

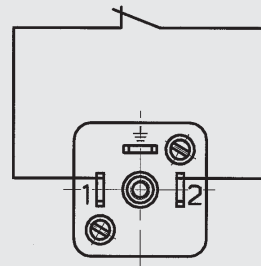

2.4.2 Switching power

2.5 A/50 V -

10,000 switching operations

0.5 A/50 V -

100,000 switching operations

2.4.3 Minimum switching current

50 mA

2.4.4 Switching tolerance

± 5 K

2.4.5 Switching hysteresis

approx. 25 K

3. DIMENSIONS

3.1. FLUID LEVEL GAUGE FSA FSA Standard

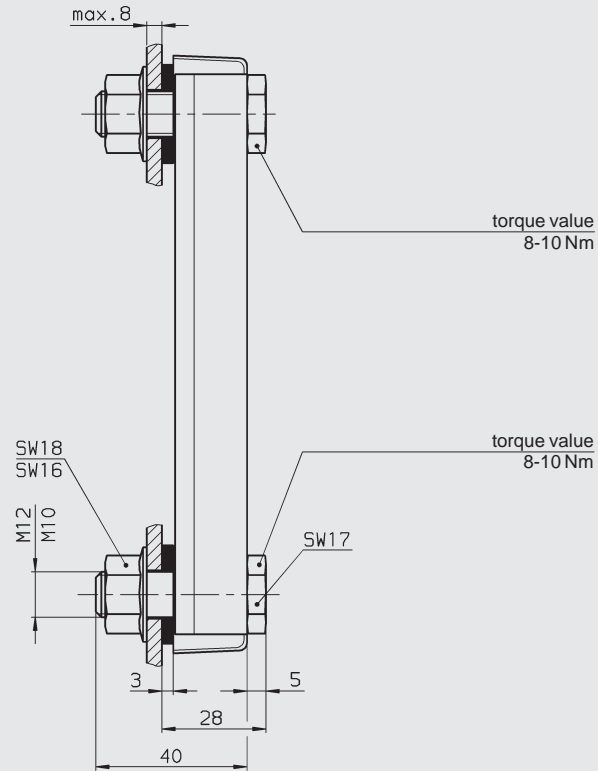
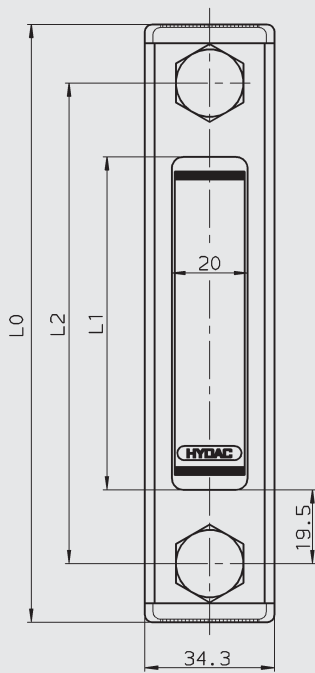

FSA with thermometer

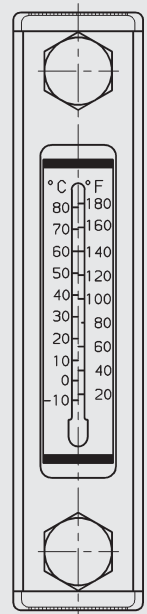

FSA with temperature switch TSE

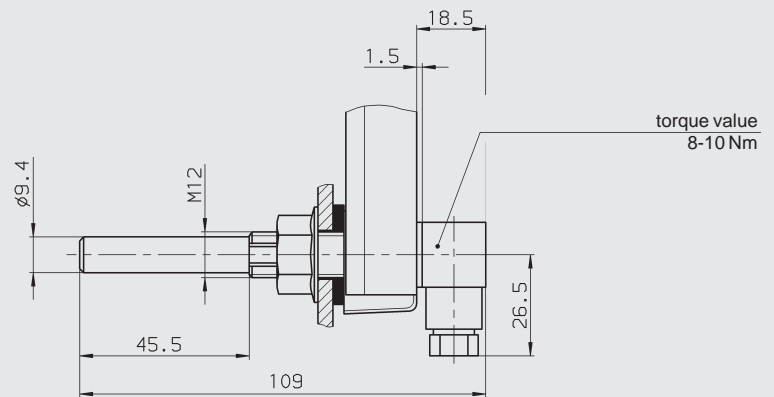
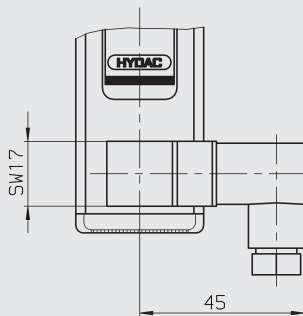

FSA / FSK with temperature gauge

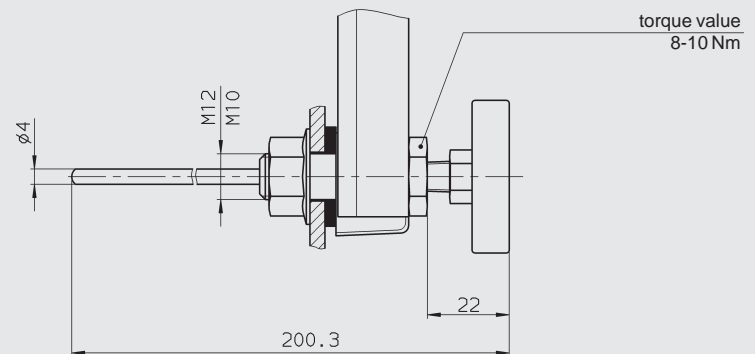
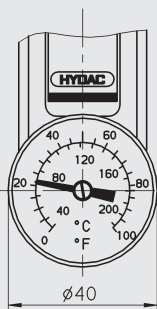

Size = centre distance of bolts	L0	L1	L2
76	107	37	76
127	158	88	127
176	207	137	176
254	285	215	254
381	412	342	381

3.2. FLUID LEVEL SENSOR FSK FSK Standard

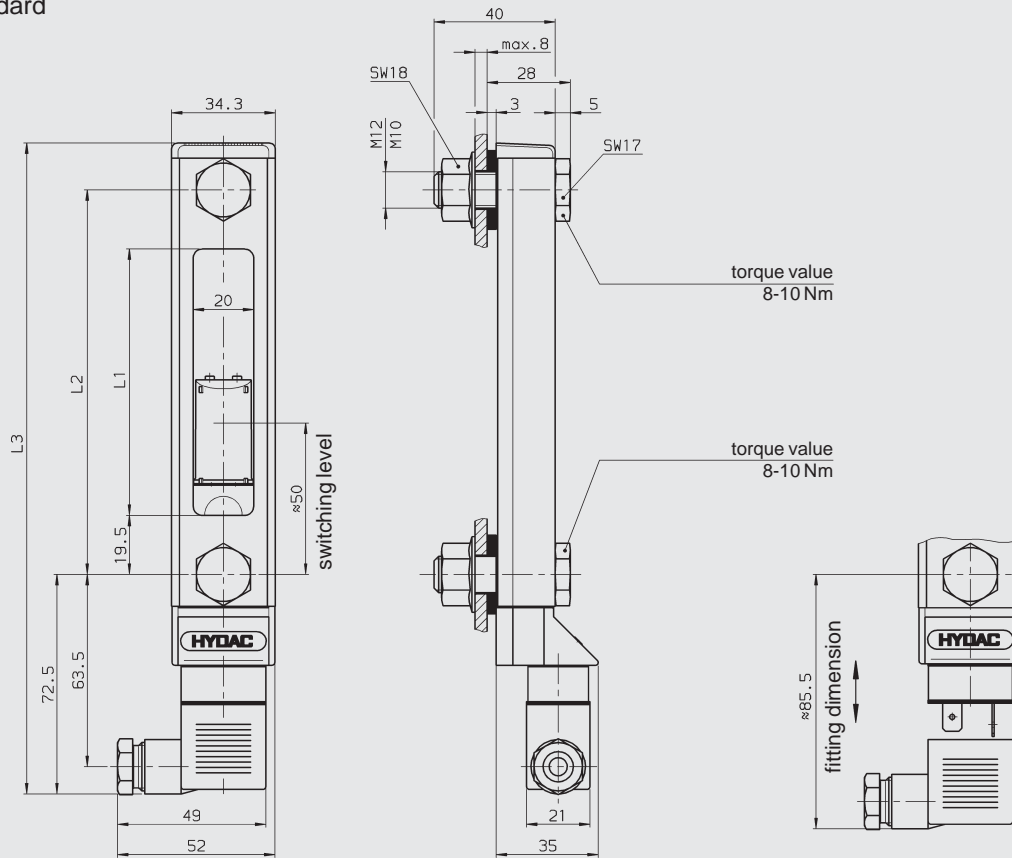

FSK Hirschmann plug Z4

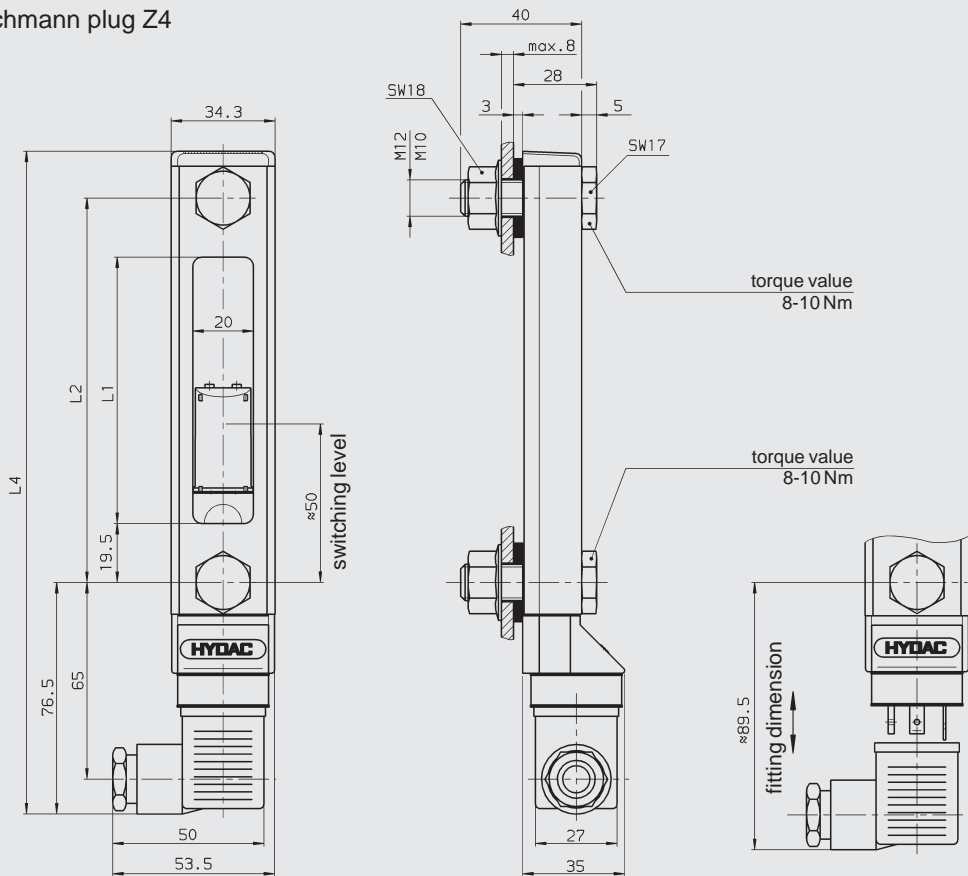

Size = centre distance of bolts	L1	L2	L3	L4
127	88	127	215	219
176	137	176	264	268
254	215	254	347	351
381	342	381	474	478

FSK Sensor technology plug M12x1

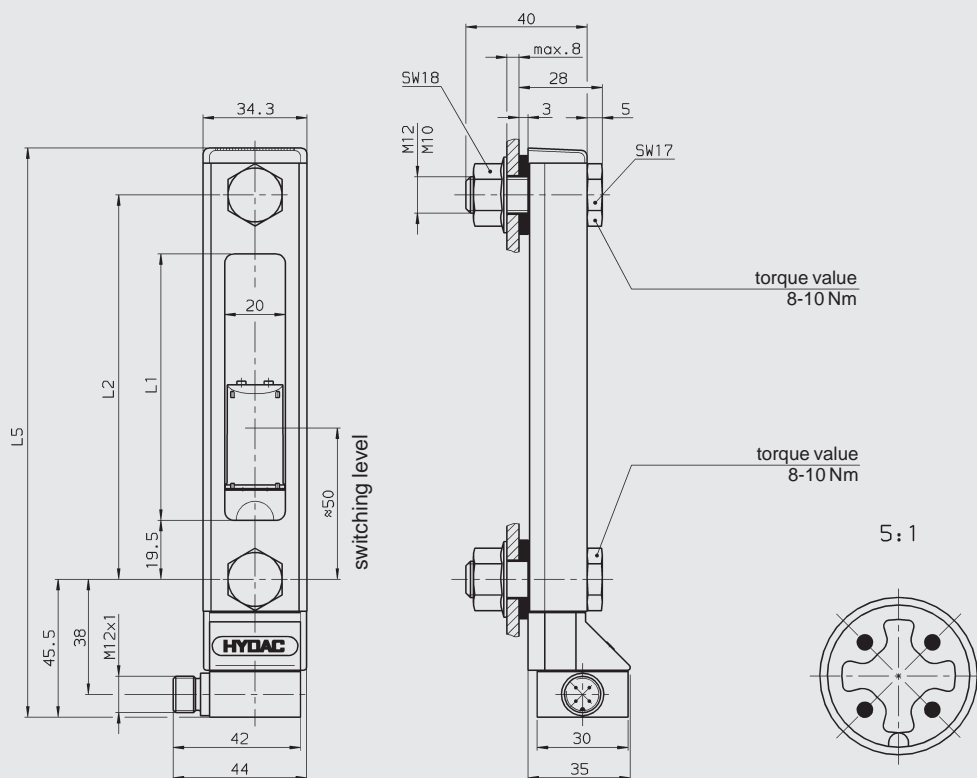

FSK with temperature switch TSE-L

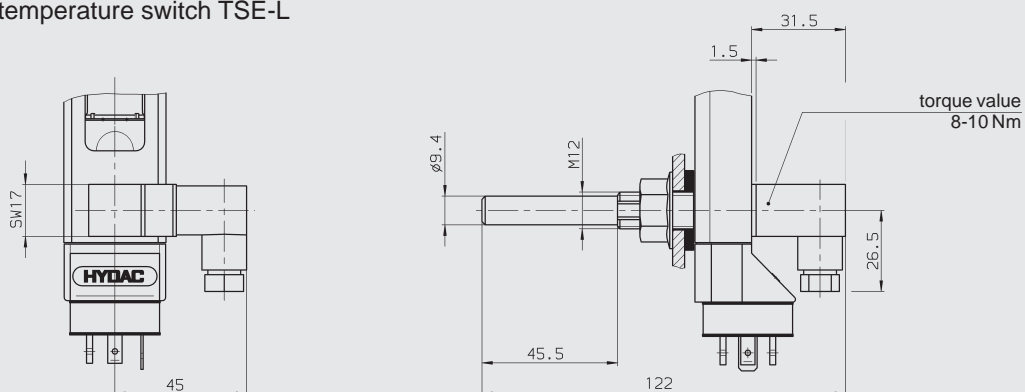

Size = centre distance of bolts	L1	L2	L5
127	88	127	188
176	137	176	237
254	215	254	320
381	342	381	447

3.3 TEMPERATURE SWITCH TSE / TSE-L

see FSA with TSE fitted
see FSK with TSE-L fitted

4. SPARE PARTS

4.1. SEAL KIT

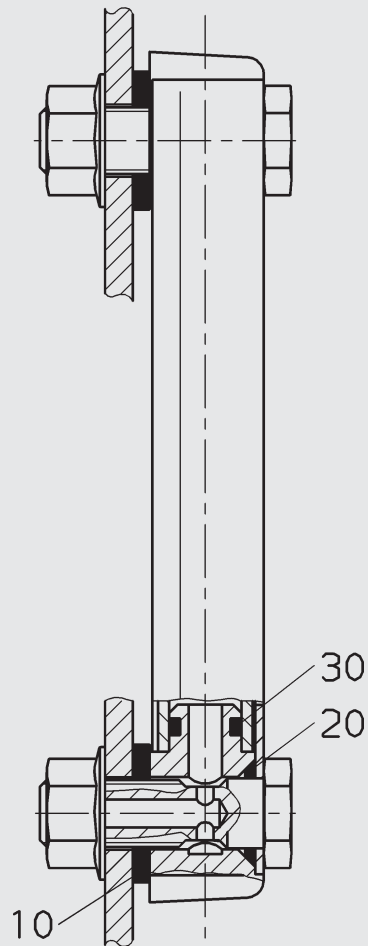

Seal kit	Order no. = Stock no.
FSA - 76 - 381 - 1.X	704 616
FSA - 76 - 381 - 2.X	704 627

5. NOTE

The information in this brochure relates to the operating conditions and applications described.

For applications or operating conditions not described, please contact the relevant technical department.

Subject to technical modifications.