

**COMPACT OIL / AIR COOLERS
NEW COMPACT DESIGN WITH
AC ELECTRIC FANS AND HIGH
COOLING PERFORMANCE**

Oil/Air Cooler Units Compact application with AC Motor OK-ELC Type

Application

These coolers are designed specifically for hydraulic applications where high performance and efficiency are required and physical size is minimised to allow easy installation. Typical applications include: industrial power units, lubrication systems (i.e. gearboxes) and machine tools.

OK-ELC Product Features

These coolers use a combination of high performance cooling elements and high capacity, compact AC electrically powered fans to give long trouble-free operation in arduous hydraulic applications.

The compact design allows the coolers to fit most equipment and provide the highest cooling performance in heat dissipation whilst minimising the space required.

- Cooling range 1-28 kW
- AC motors in 230/400 Volt 50/60 Hz
- Hydraulic pressure 16 bar dynamic



Test procedure certified following EN 1048



OIL/AIR COOLER

DESCRIPTION

GENERAL

In hydraulic systems energy is transformed and transmitted. During this transformation and transmission losses occur, i.e. mechanical and hydraulic energy is converted into heat. It is the function of the cooler to dissipate this heat.

ADVANTAGES OF THE OIL/AIR COOLERS:

- Environmentally friendly. No exchange between water and oil possible
- For commissioning only electrical energy is required
- Low operating costs, no additional cooling circuit necessary for the cooling medium, i.e. air

CONSTRUCTION

Oil/air cooler units consists of the (1) heat exchanger, (2) housing (3) axial motor fan. The oil connections are on the rear side.

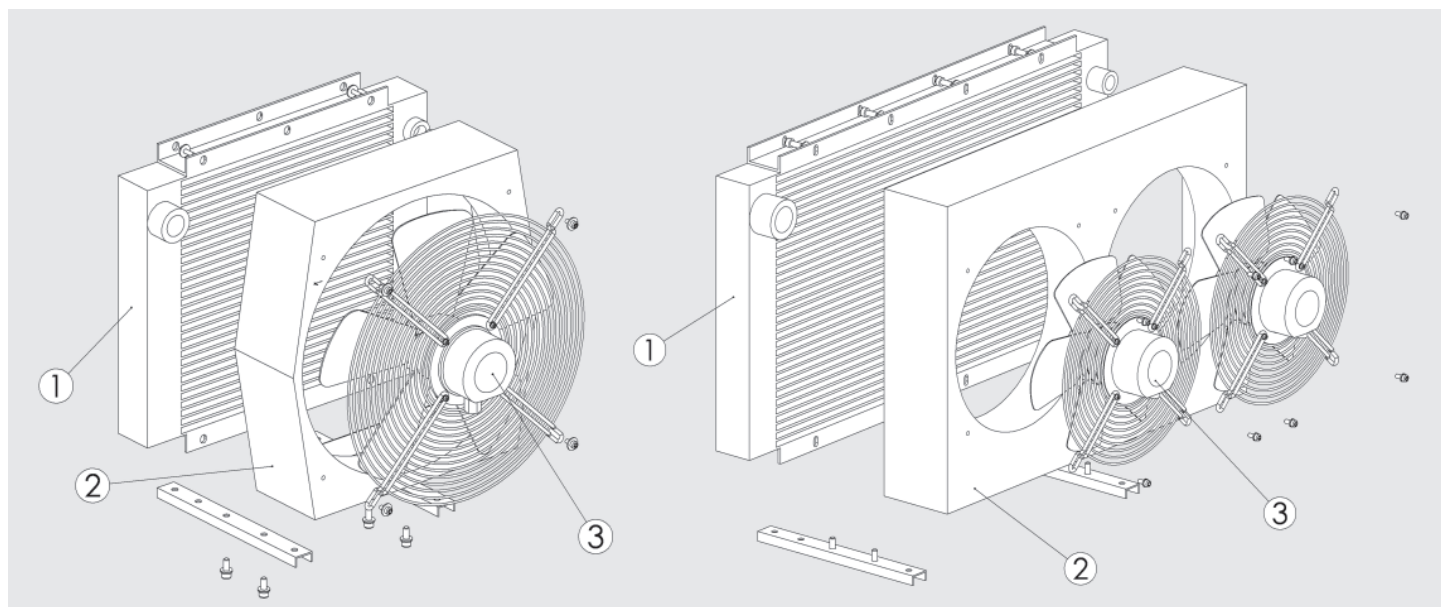
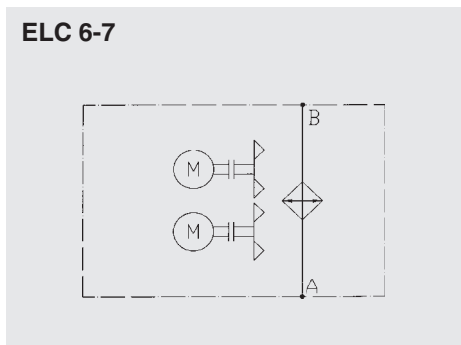
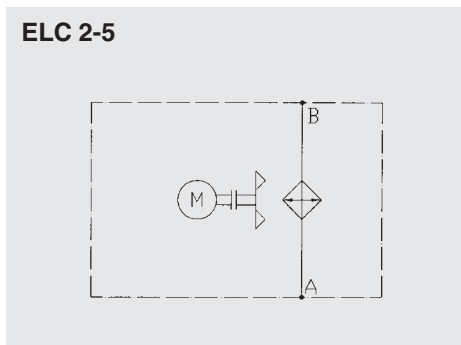
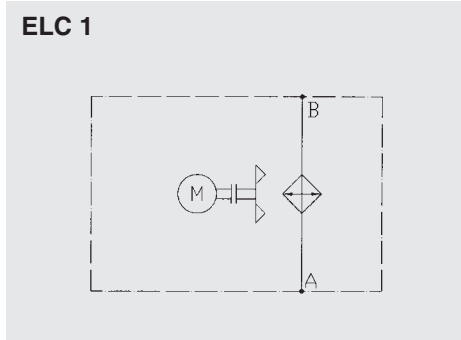
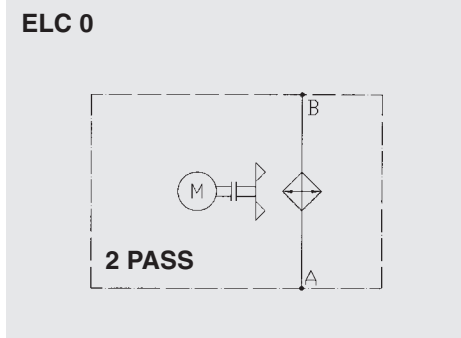
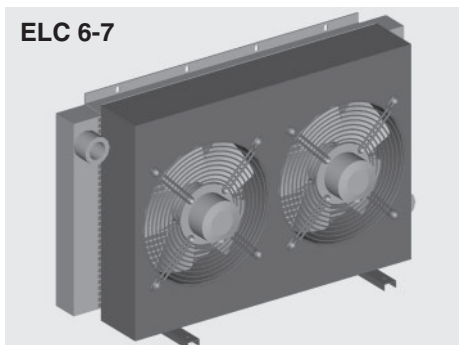
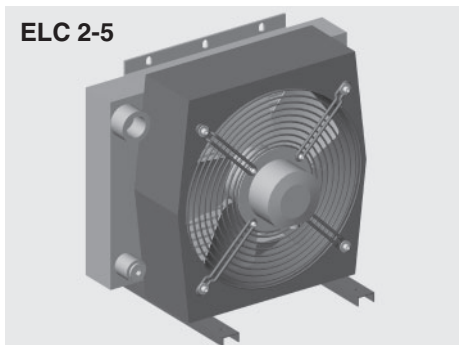
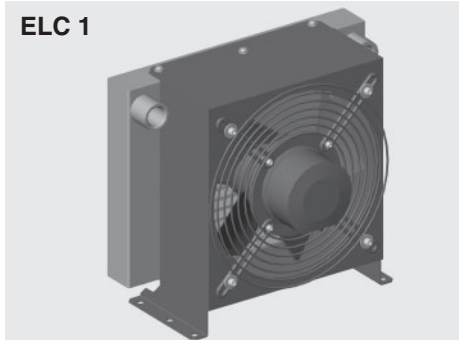
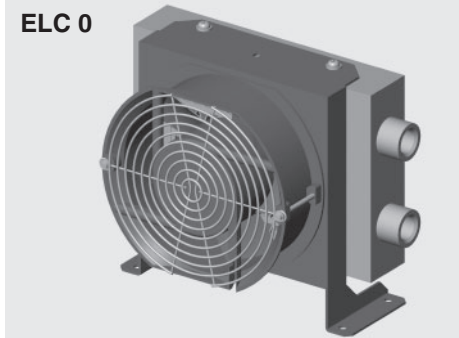

COOLER SELECTION

Designation:

P_v = Power loss [kW]

P_{01} = Specific cooling capacity [kW/°C]

V = Tank contents [l]

ρ_{oil} = Density of the oil [kg/l]
for mineral oil: 0.915 kg/l

C_{oil} = Specific heat capacity [kJ/kgk]
for mineral oil 1.88 kJ/kgk

ΔT = Temperature increase in the system [°C]

t = Operating time [min]

T_1 = Desired oil temperature [°C]

T_3 = Ambient temperature [°C]

Example 1:

Measurement of the power loss on existing units and machinery. For this method the temperature increase of the oil is measured over a certain period. The power loss can be calculated from the temperature increase.

Parameters:

The oil temperature increases from 20 °C to 45 °C over 15 minutes.

The tank contains 100 l.

Heat to be dissipated:

$$P_v = \frac{\Delta T \times c_{oil} \times \rho_{oil} \times V}{t \times 60} \quad [\text{kW}]$$

$$P_v = \frac{25 \times 1.88 \times 0.915 \times 100}{15 \times 60} = 4.78 \quad [\text{kW}]$$

Cooler selection:

– Desired oil temperature: 60 °C
– Ambient temperature air: 30 °C

$$P_{01} = \frac{P_v}{T_1 - T_3} \quad [\text{kW/°C}]$$

$$P_{01} = \frac{4.78}{60 - 30} = 0.159 \quad [\text{kW/°C}]$$

A 10% safety margin is recommended to allow for element contamination, and therefore the specific power is:

$$P_{01} \times 1.1 = 0.175 \text{ kW/°C.}$$

The power loss 0.175 kW/°C must be dissipated by an oil cooler.

Suggestion:

–Cooler OK-ELC3H,
 $P_{01} = 0.2 \text{ kW/°C at } 40 \text{ l/min}$

Example 2:

The power loss can also be estimated. With unrestricted flow approx. 15 to 20% of the drive power. With restricted flow up to 30% of the drive power.

1. TECHNICAL DETAILS

1.1. TABLE OF TECHNICAL SPECIFICATIONS

Type of cooler	Voltage [V]	Oil flow at 1.5 bar pressure drop [l/min]	N° of poles	Motor Capacity at 50Hz [W]	Speed at 50 Hz [rpm]	Capacitor [μ F/VDB]	Protection class IP [-]	Noise level [dB(A)] (at 1m distance)	Max. operating pressure [bar]	Max. oil temperature [°C]	Max. Viscosity [mm ² /s]	Weight [kg]
ELC0H	230	20	2	35	2800	–	20	59	16	130	2000	3.2
ELC1H	230	120	2	120	2700	2/450	55	71	16	130	2000	9
ELC1H	400	120	2	115	2600	2/500	55	71	16	130	2000	9
ELC2H	230	210	2	120	2600	2/450	55	71	16	130	2000	11.9
ELC2H	400	210	2	140	2500	2/500	55	71	16	130	2000	11.9
ELC3H	230	220	2	170	2600	4/450	55	75	16	130	2000	14.7
ELC3H	400	220	2	188	2500	3/500	55	75	16	130	2000	14.7
ELC4S	230	190	4	210	1400	4/450	55	69	16	130	2000	21
ELC4S	400	190	4	230	1380	–	55	69	16	130	2000	21
ELC5S	230	270	4	210	1400	4/450	55	72	16	130	2000	28
ELC5S	400	270	4	230	1380	–	55	72	16	130	2000	28
ELC6H	230	180	2	2X 170	2600	2X 4/450	55	75	16	130	2000	39
ELC6H	400	180	2	2X 188	2500	2X 3/500	55	75	16	130	2000	39
ELC7S	230	140	4	2X 210	1400	2X 4/450	55	71	16	130	2000	45
ELC7S	400	140	4	2X 230	1380	–	55	71	16	130	2000	45

– ELC0: the electrical connection wires are provided

– ELC1-7: the electrical connection box is included

– Capacitor is supplied with the cooler and mounted in the connection box when required

– All motors with IP55 have protection class F, except ELC0 with IP20

– Mounting position: all positions possible

– For direction of rotation see arrow on cooler housing

– Cooling fluid

Mineral oil to DIN 51524

For other fluids, please contact our sales/technical department

– The noise levels are only a guide as acoustic properties vary and depend on the characteristics of the room, connections, viscosity and resonance.

– Options: see accessory catalogue

Warning!

When operating a cooler in situations where the difference in temperature between ambient air and inlet oil exceed 50 Deg. Celsius, care must be taken to avoid cycling of the fan at full speed/air flow as this can cause rapid change in material temperature of element and may result in significant reduction in lifetime or direct damage to the element through thermal stress.

Please contact your Hydac Branch or distributor for speed control solutions.

1.2. HYDRAULIC DETAILS

1.2.1 Cooling capacity

depending on oil flow and the temperature differential ΔT between the oil inlet and air inlet.

For calculations with low ΔT values (i.e. below 10 °C), please contact our technical support staff.

Tolerance: $\pm 5\%$

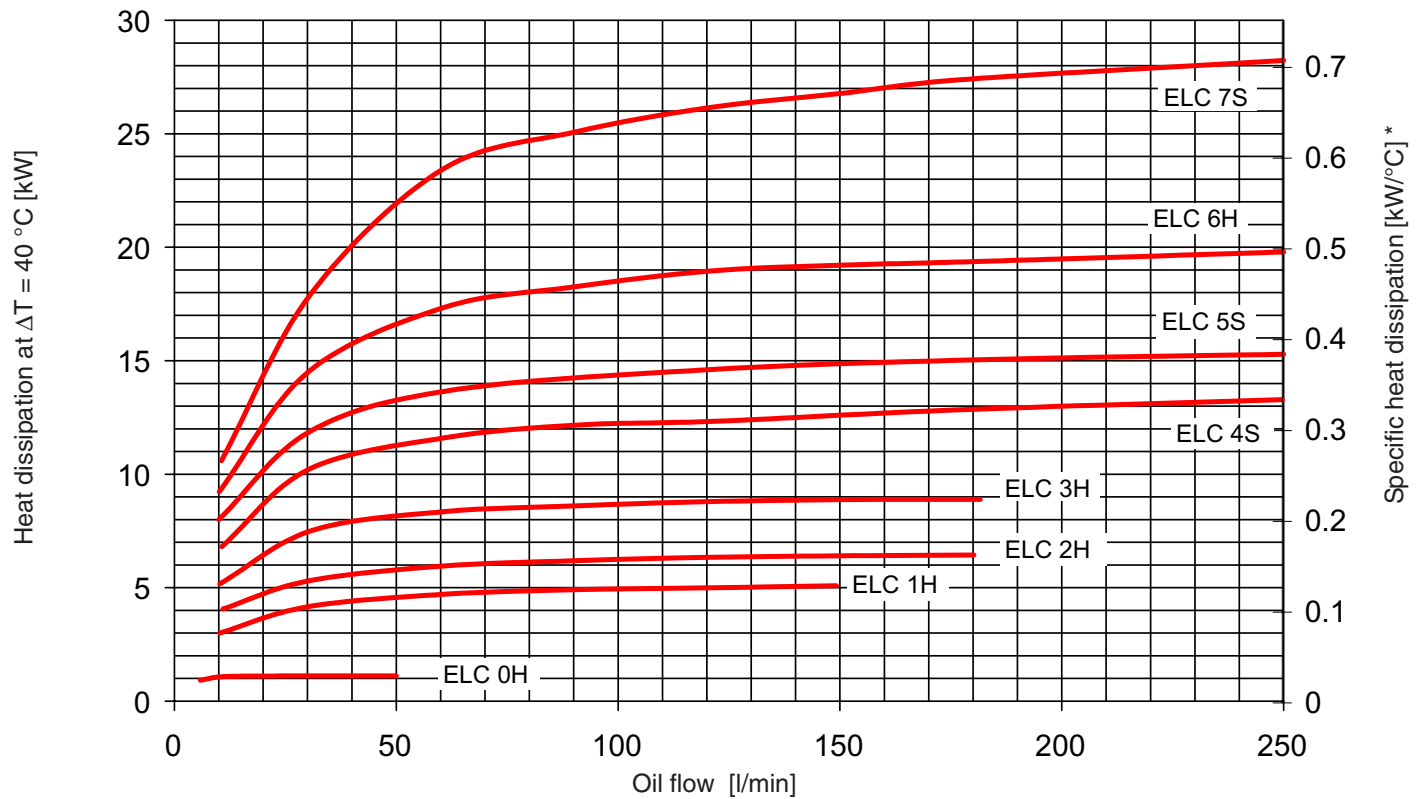

* Values measured at $\Delta T = 40\text{ °C}$, may vary at lower ΔT values

1.2.2 Pressure differential Δp measured at 30 mm²/s using mineral oil

Tolerance: $\pm 5\%$

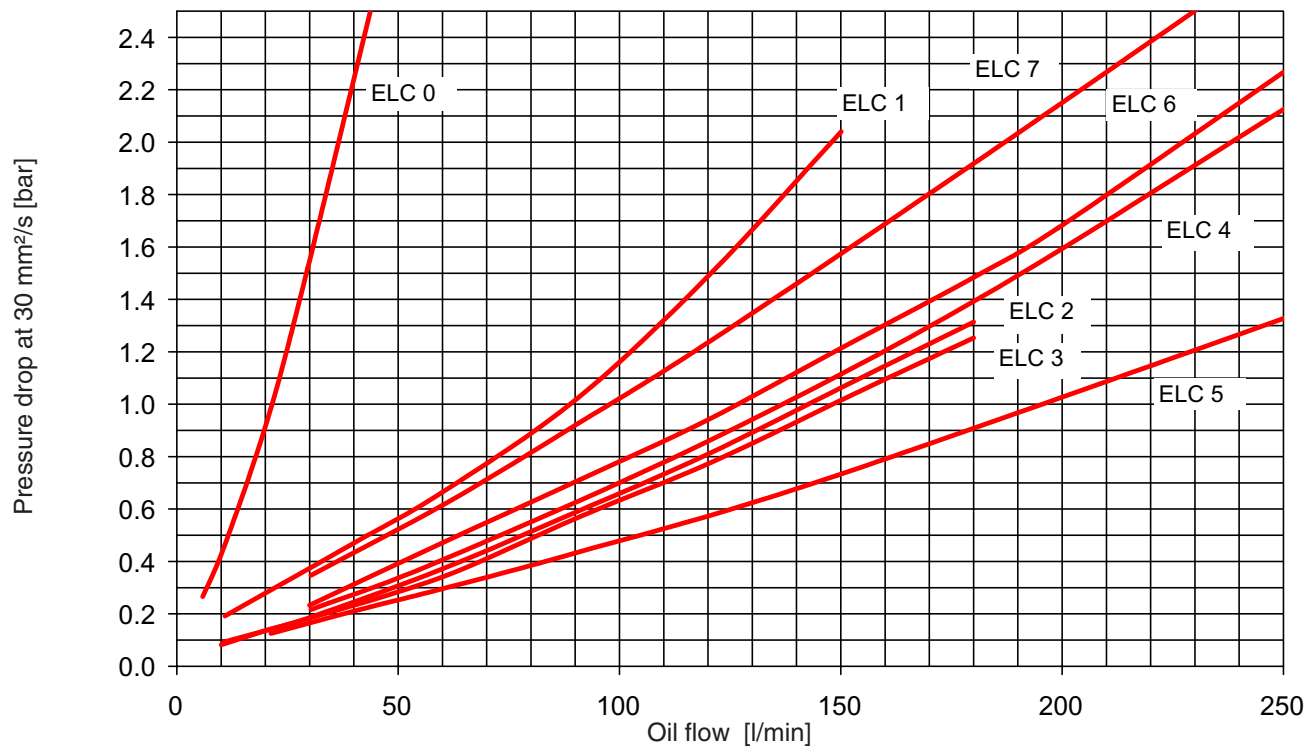

For other viscosities the result must be multiplied by K

Viscosity (mm ² /s)	10	15	22	30	46	68	100	150
Factor K	0.35	0.5	0.75	1	1.4	1.9	2.5	3.5

2. MODEL TYPE

(also order example)

OK-ELC2H / 1.0 / 230V / 1 / S / AITF50

Type of cooler

OK-ELC = Oil/air cooler

Size / motor speed

0:7 = See hydraulic details 1.2

H = 3000 min⁻¹

S = 1500 min⁻¹

Type code and modification number

Electrical motor fan voltage

230V = 230 Volts 50/60 Hz

400V = 400 Volts 50/60 Hz

Paint

1 = RAL 9005 (Standard)

Other paint on request and clearly written

Air flow direction

S = Suction (Standard)

Accessories (for more information see accessories brochure)

AITF50 = Thermostat (fixed)

IBP = Heat exchanger with integrated bypass valve (not available for ELC0 and ELC1)

IBT = Heat exchanger with integrated thermo-bypass valve (not available for ELC0 and ELC1)

GP = Vibration absorber

3. DIMENSIONS

3.1. ELC0

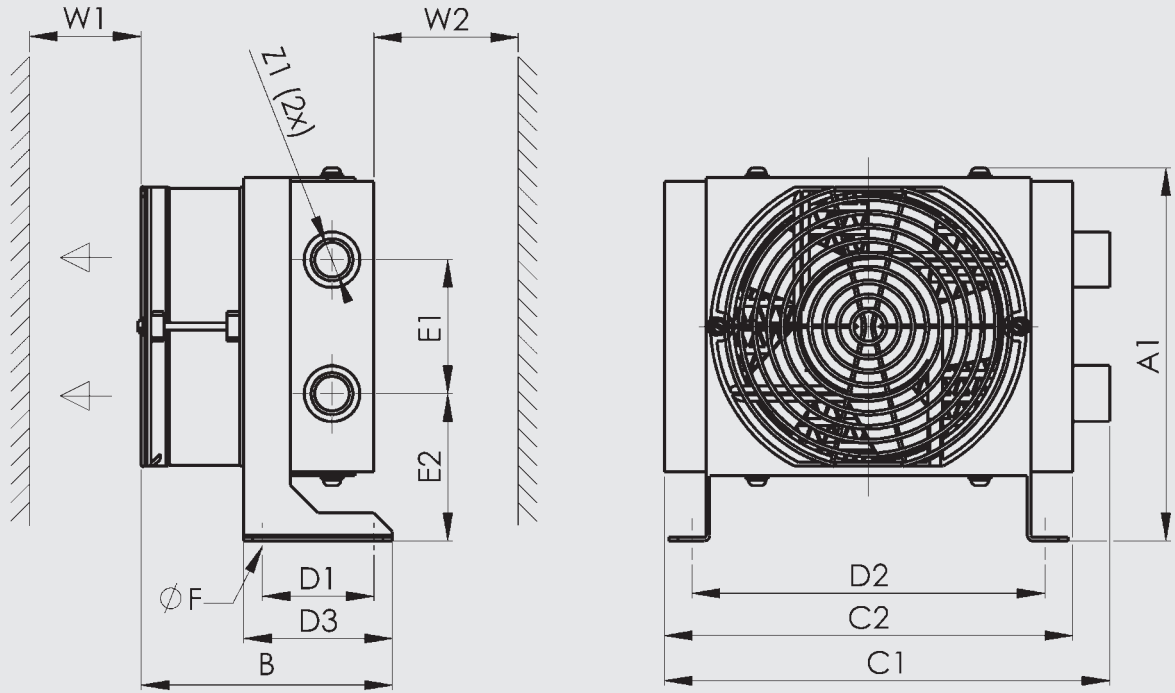

	A1	B	C1	C2	D1	D2	D3	E1	E2	W1	W2	Z1	F
	±5	±10	±4	±4	±1	±2	±2	±2	±5	min	min		4xØ
ELC0	202	138	240	220	60	190	80	72	79	150	50	G1/2"	6.5

3.2. ELC1

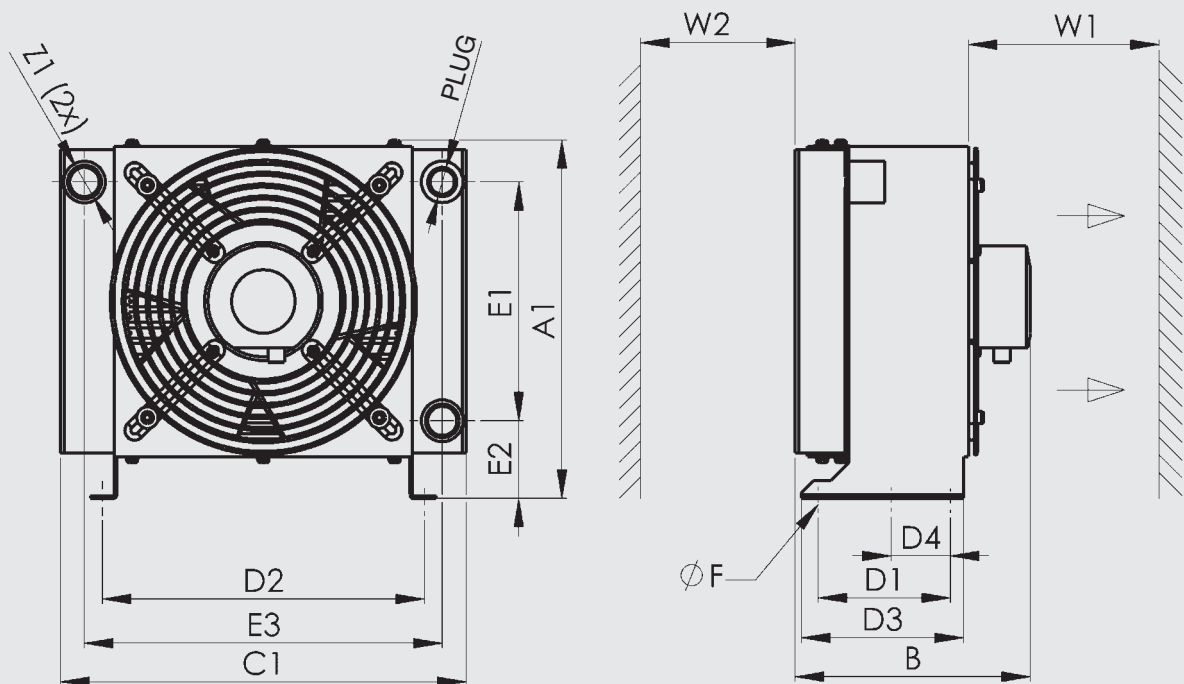

	A1	B	C1	D1	D2	D3	D4	E1	E2	E3	W1	W2	Z1	F	Plug
	±5	±10	±8	±2	±2	±2	±2	±5	±5	±5	min	min		6xØ	
ELC1	300	205	340	110	270	136	50	200	65	300	200	70	G3/4"	8.5	M22X1.5

3.3. ELC2-5

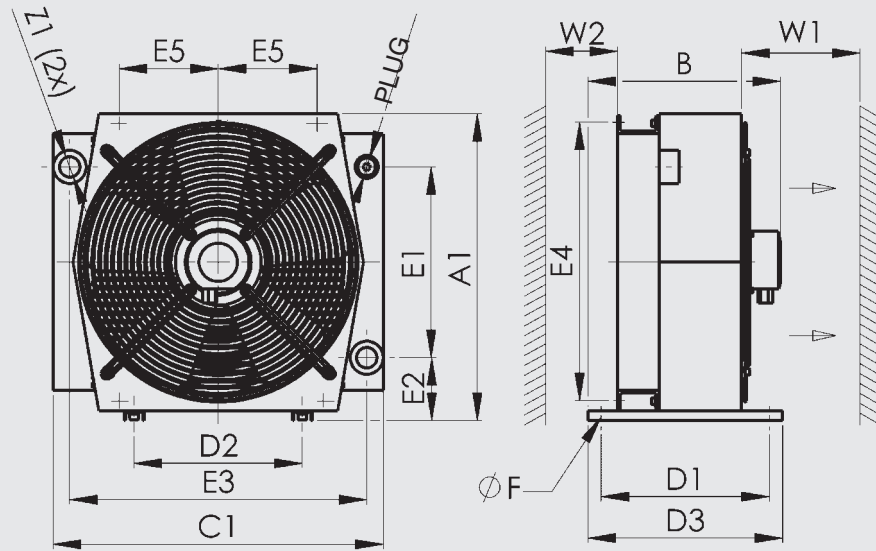

	A1 ±5	B ±10	C1 ±5	D1 ±2	D2 ±3	D3 ±3	E1 ±5	E2 ±5	E3 ±5	E4 ±2	E5 ±2	W1 min	W2 min	Z1	F 6xØ	Plug
ELC2	328	295	384	255	160	295	199	72	324	288	80	250	150	G1"	14x10	M22X1.5
ELC3	371	287	420	255	240	295	230	78	370	329	100	300	180	G1"	16x9	M22X1.5
ELC4	465	292	500	255	255	295	289	96	450	421	150	400	200	G1"	16x9	M22X1.5
ELC5	475	306	602	255	255	295	350	70	490	200*	580*	400	250	G1 1/4"	12	M22X1.5

* : ELC5 has the front fixing holes in the lateral sides.

3.4. ELC6-7

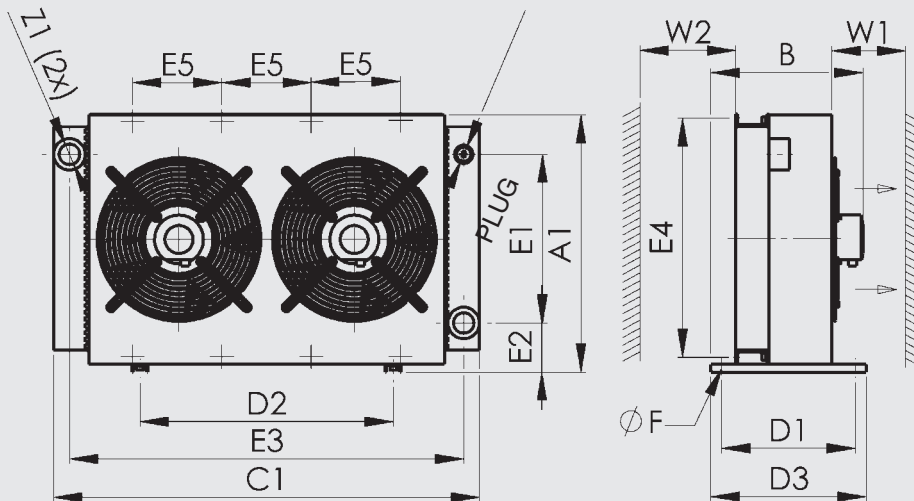

	A1 ±5	B ±10	C1 ±8	D1 ±3	D2 ±3	D3 ±3	E1 ±5	E2 ±5	E3 ±5	E4 ±2	E5 ±2	W1 min	W2 min	Z1	F 8xØ	Plug
ELC6	495	286	810	255	482	295	321	91	750	450	170	400	200	G1 1/4"	16x9	M22X1.5
ELC7	547	289	950	255	482	295	373	94	890	503	200	503	250	G1 1/4"	18x9	M22X1.5

4. CERTIFICATION FOLLOWING EN 1048

Hydac SA design and manufacture high quality coolers that are tested and certified to give reliable and repeatable high performance. To ensure the performance is accurate, testing in compliance with a recognized international test standard is the best solution. For air/liquid coolers this is EN1048.

Hydac SA test procedure complies with the requirements of EN 1048 and both the procedure and test equipment are independently inspected and certified by TÜV SÜDDEUTSCHLAND.

The cooler performance details in this brochure have been tested following EN 1048.



5. NOTE

The information in this brochure relates to the operating conditions and applications described. For applications or operating conditions not described, please contact the relevant technical department. Subject to technical modifications.